

SERMES

motorisation

IE3 IP55 400V
50Hz

FACILITÉ DE MONTAGE

Arbre creux ou arbre sortant
Livré avec lubrifiant
Lubrifié à vie
Montage intégré
Compacité

MODULARITÉ

2 étages combinés
Carter en fonte
Facteur de service élevé
Rendement élevé

POLYVALENCE

Couple maxi 1350 N.m
Puissance de 0,12 à 7,5kW
Rapport jusqu'à 183
Rapport combiné jusqu'à 19466

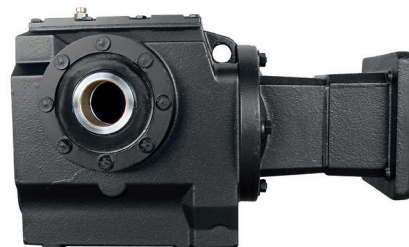
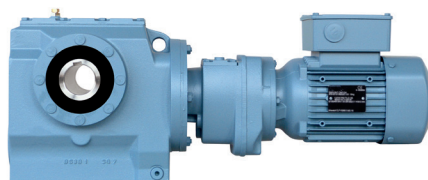
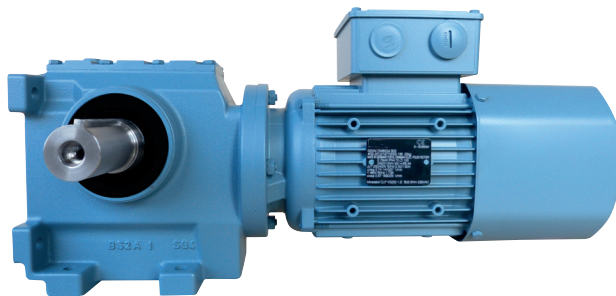

La largeur de gamme

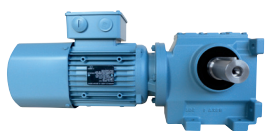

Type S

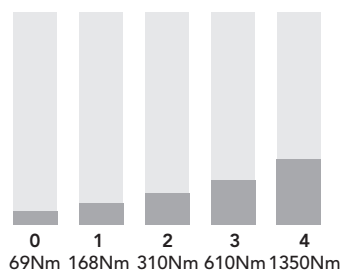

Options principales

- Frein
- Ventilation forcée
- Codeur
- ATEX
- Montage servo-moteur
- Bride d'entrée IEC ou Nema
- Arbre primaire
- Bras de couple
- Palier renforcé

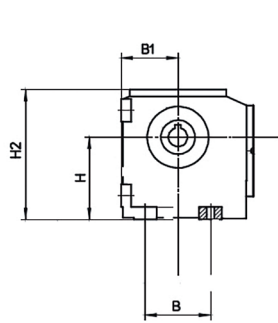

A pattes

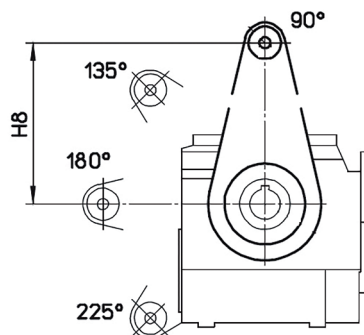
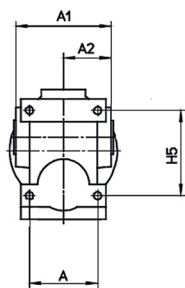

Bras de couple

Type	à pattes										BRAS
	Arbre creux	Arbre sortant	H	B	A	B1	H5	H2	A1	A2	
S0	20	20x40	70	60	50	52	86	113	86	43	100
S1	25	25x50	95	75	90	70	95	151,5	116	58	130
S2	30	30x60	120	90	110	85	120	191	144	72	160
S2	35	35x70	120	90	110	85	120	191	144	72	160
S3	40	40x80	145	115	120	100	150	229,5	168	84	200
S4	50	50x100	180	135	150	125	180	280	202	101	250

Type	Bride de sortie B14 - FT				
	FT74	FT87	FT96	FT106	FT130
S0	B				
S1		B			
S2			B		
S3				B	
S4					B

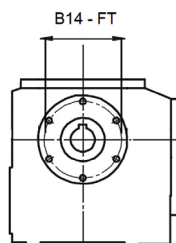

Type	Bride de sortie B5-FF			
	FF130	FF165	FF165	FF215
Taille Bride	70	83	95	113
Prof cote A4	E			
S1	E			
S2		E		
S3			E	
S4				E

